

FGH 2.0

EXPANSION JOINT COVERS WITH HYGIENIC REQUIREMENTS

MIGUTEC

JOINT COVERS FOR EXPANSION JOINTS

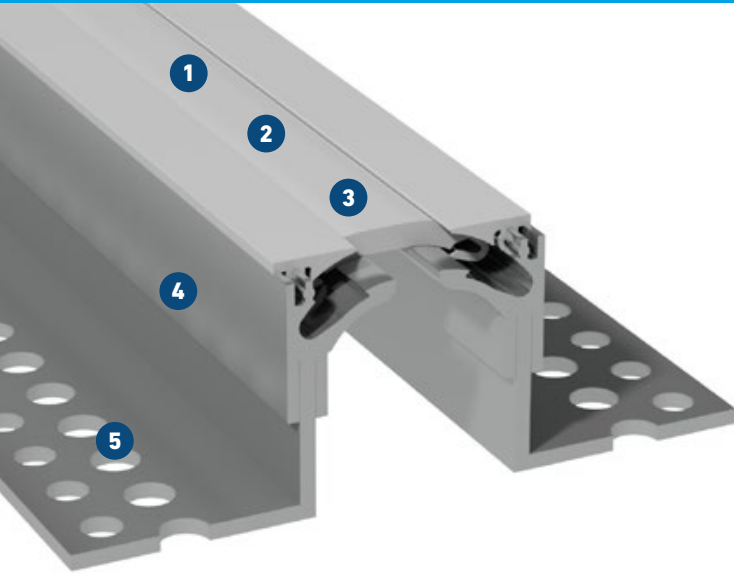

- 1 Ultra-smooth insert for residue-free cleaning**
Ensures optimal sterility and is physiologically safe
- 2 Seamless, symmetrical visible surface**
Hard-wear special insert for smoother, low-noise transit
- 3 New: Innovative clip design**
Insert is fully replaceable over entire length of expansion joint cover
- 4 Secure fixing due to MultiHole mounting bracket**
Flexible anchoring and excellent bond
- 5 Innovative solution**
Suitable for hospital-typical vehicles, such as hospital beds and food trolleys

| Expansion joint cover | Joint width | Total movement | Visible width | Total width | Joint height | Load bearing capacity* | Load bearing capacity* |
|-----------------------|---------------------------|----------------------|---------------|---------------|--------------|------------------------|------------------------|
| | $b_f \text{ max}$ [mm] | Δb_f [mm] | b_s [mm] | b_t [mm] | h [mm] | [kN] | [kN] |
| FGH2 65/30 | 50 | 20 (± 10) | 65 | 148 | 30 | 30 | |
| FGH2 65/38 | 50 | 20 (± 10) | 65 | 148 | 38 | 30 | |
| FGH2 65/50 | 50 | 20 (± 10) | 65 | 171 | 50 | 30 | |
| FGH2 65/60 | 50 | 20 (± 10) | 65 | 171 | 60 | 30 | |
| FGH2 65/70 | 50 | 20 (± 10) | 65 | 171 | 70 | 30 | |

* no continuous use

All information on load bearing capacity does only apply to non-floating floors.

Larger installation heights on request.

Production length: 3 m

Standard colours: black, grey

Wall connections: E3, E4

